



# SLM6510

## 2A Synchronous Buck Li-Ion Battery Charger

### Description

The SLM6510 is a 2A single cell Li-ion battery charger applied for 5V wall adapters. It utilizes 1.5MHz synchronous buck converter topology to reduce power dissipation and therefore reaches a high efficiency up to 90%.

The SLM6510 includes complete charge termination circuitry, automatic recharge, and a  $\pm 1\%$  4.2V float voltage. It also has other features include output short-circuit protection, battery temperature monitor, overheating protection, and no blocking diode is required.

The SLM6510 is available in DFN8 package with heat sink. Its few external component count makes the SLM6510 a high-efficient battery charger ideally suited for portable applications.

### Absolute Maximum Ratings

- Vcc: -0.3V~8V
- BAT: -0.3V~7V
- LX: -0.3V~7V
- VS: -0.3V~7V
- NCHRG: -0.3V~8V
- NSTDBY: -0.3V~8V
- TS: -0.3V~8V
- BAT Short-Circuit Duration: Continuous
- Maximum Junction Temperature: 145°C
- Operating Temperature Rang: -40°C~85°C
- Storage Temperature Range: -65°C~125°C
- Lead Temperature (Soldering, 10 sec) 260°C

### Features

- 1.5MHz Fixed Switching Frequency
- High Efficiency up to 90%
- 2.5A Maximum Charge Current
- No External MOSFET or Blocking Diode Required
- Preset 4.2V Charge Voltage with  $\pm 1\%$  Accuracy
- Automatic Recharge
- Charge State Pairs of Output, No Battery and Fault Status Display
- C/10 Charge Termination
- 140uA Supply Current in Shutdown
- 2.9V Trickle Charge
- Soft-Start Limits Inrush Current
- Battery Temperature Monitoring
- Short-Circuit Protection
- Available in 8-Pin DFN8 Package

### Applications

- Cellular Telephones
- MP3, MP4 Players
- GPS, Digital Cameras
- Electronic Dictionaries
- Portable Devices, Chargers

### Complete Charge Cycle

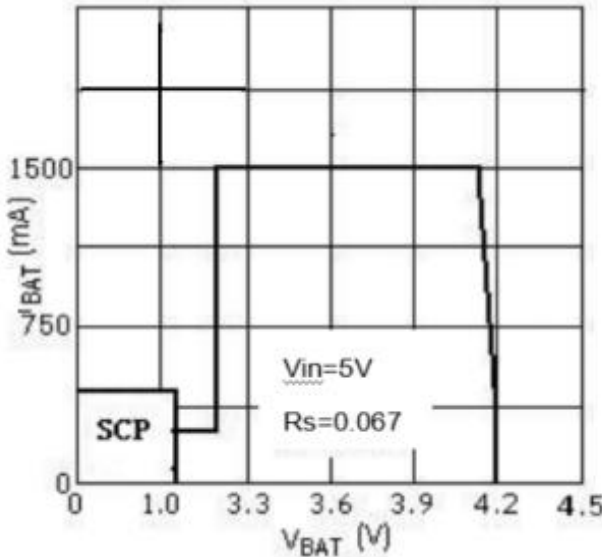

Figure 1

### Typical Application

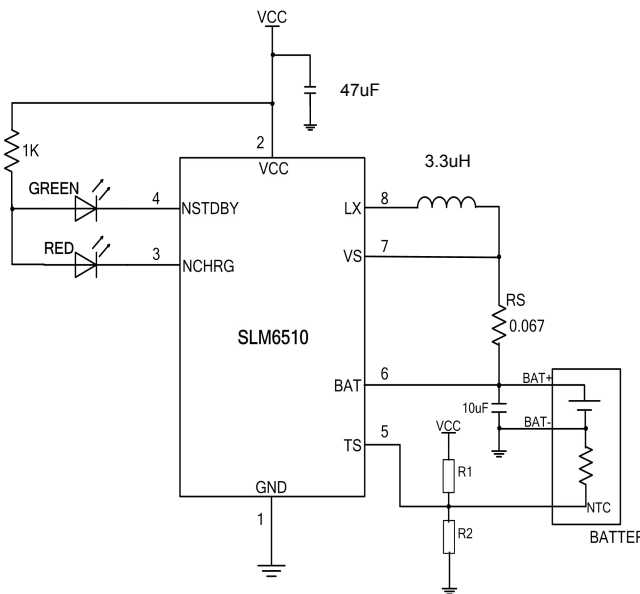

Figure 2

### Application Tips

Effective heat dissipation is the key to ensure the chip to long-term maintain high charge current.

In order to maximize the charge current, PC board layout design should be optimized to provide IC within DFN8 package effective heat dissipation.

The thermal path for the heat generated by IC is from the die to lead frame, and finally to the PC board copper through the bottom heat sink. As the heat sink of IC, the copper pads of PC board should be as wide as possible, and extends out to other larger copper areas to dissipate heat into ambient environment.

Another effective way to improve the heat dissipation ability of charger is to placing via to the internal or back layer of PC board, as figure 3 illustrates, place a pad as the heat sink of SLM6510, and then place 4 cooling holes spacing on the pad. Solder should be injected into the cooling holes from the back layer of PC board to ensure that the bottom heat sink of SLM6510 is effectively connected to the cooling pad.

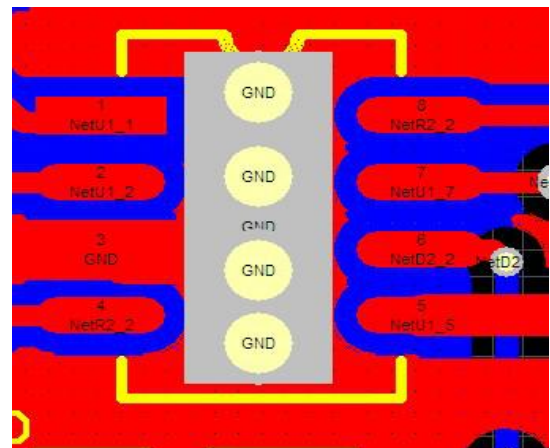

Figure 3

Other heat sources not related to the IC should also be considered when designing PC board layout, as they might influence the overall temperature rise and the maximum charge current.

### Pin Configuration

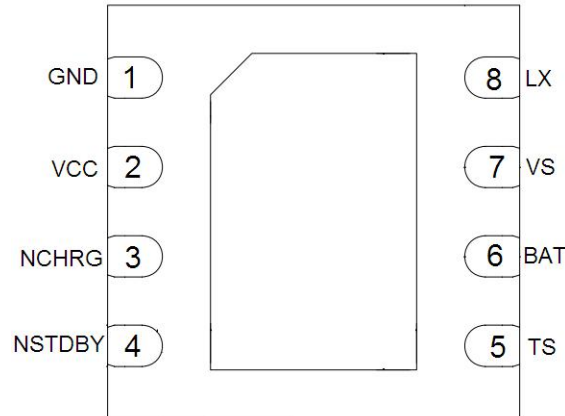

Figure 4. SLM6510 Package

Pin	Symbol	Function
1	GND	Ground
2	Vcc	Positive input supply voltage
3	NCHRG	Open-Drain charge status output
4	NSTDBY	Charge terminated status output
5	TS	Chip enable and battery temperature sense
6	BAT	Battery connection Pin
7	VS	Charge current sense
8	LX	Switching

### Pin Assignment

**GND(Pin 1):** Ground.

**Vcc(Pin 2):** Positive input supply voltage. It provides power to the internal circuit. When VCC drops to within 30mV of the BAT pin voltage, the SLM6510 enters low power mode, dropping IBAT to less than 2 $\mu$ A.

**NCHRG (Pin 3) :** Open-Drain charge status output. When the battery is being charged, the NCHRG pin



## *SLM6510* *2A Synchronous Buck Li-Ion Battery Charger*

---

is pulled low by an internal switch to indicate the charge. Otherwise, NCHRG pin is in high impedance state.

**NSTDBY(Pin 4):** Charge terminated status output. NSTDBY is pulled low by an internal switch to indicate the termination of battery charge. Otherwise NSTDBY pin is in high impedance state.

**TS(Pin 5):** Chip enable and battery temperature sense input. Connecting TS pin to NTC sensor's output in Lithium ion battery pack. If TEMP pin's voltage is below 45% or above 80% of supply voltage VCC, this means that battery's temperature is too low or too high, charging is suspended. The temperature sense function can be disabled by connecting it to Vcc pin. Grounding TS pin will make the chip disable and terminate the charge.

**BAT(Pin 6):** Battery connection Pin. Connect the positive terminal of the battery to this pin. Dropping BAT pin's current to less than 2 $\mu$ A when IC in disable mode or in sleep mode. BAT pin provides charge current to the battery and provides regulation voltage of 4.2V.

**VS(Pin 7):** Charge current sense pin.

**LX(Pin 8):** External inductor connecting pin.



# SLM6510

## 2A Synchronous Buck Li-Ion Battery Charger

### DC Characteristics

(Note: TA=25°C, VCC=5V, unless otherwise specified)

Symbol	Parameter	Condition	Min	Typ.	Max	Unit
Vcc	Input supply voltage		3.8	5	6.5	V
Icc	Input supply current	Charge mode		250	500	uA
		Standby mode (charge ends)		220	280	uA
		Shutdown mode (RPROG not connected, Vcc<VBAT or VCC<VUV)		190	280	uA
VFLOAL	Regulated output voltage	0°C≤TA≤85°C	4.158	4.2	4.242	V
IBAT	BAT pin current (Test condition of current mode is VBAT=3.8V)	RPROG=0.1ohm,current mode	900	1000	1100	mA
		RPROG=0.05ohm,current mode	1800	2000	2200	mA
		Standby mode, VBAT=4.2V	0	-2.7	-5	uA
		Shutdown mode (RPROG not connected)		±1	±2	uA
ITRIKL	Trickle charge current	VBAT<VTRIKL, RPROG=0.05ohm	140	200	260	mA
VTRIKL	Trickle charge threshold voltage	RPROG=0.05ohm, VBAT rising	2.8	2.9	3.0	V
VTRHYS	Trickle charge hysteresis voltage	RPROG=0.05ohm	60	100	140	mV
VUV	VCC under voltage lockout threshold	Vcc from low to high	3.55	3.7	3.85	V
VUVHYS	VCC under voltage lockout hysteresis		150	200	300	mV
VASD	VCC-VBAT lockout threshold voltage	Vcc from low to high	120	200	300	mV
		Vcc from low to high	20	40	60	mV
ITERM	C/10 termination current threshold	RPROG=0.1ohm		100		mA
		RPROG=0.05ohm		200		mA
V <sub>NCHRG</sub>	NCHRG Pin output low voltage	INCHRG=5mA		0.3	0.6	V
V <sub>NSTDBY</sub>	NSTDBY Pin output low voltage	INSTDBY=5mA		0.3	0.6	V
VTS-H	The voltage at TS			80	82	%Vcc



# SLM6510

## 2A Synchronous Buck Li-Ion Battery Charger

	increase					
VTS-L	The voltage at TS decrease		43	45		%Vcc
$\Delta$ VRECHRG	Recharge battery threshold voltage	VFLOAT-VRECHRG	140	200	320	mV
Fosc	Switching frequency		1.3	1.5	1.7	MHz
TLIM	Thermal protection temperature			145		°C
RPFET	The on-resistance of P-FET			150		m $\Omega$
RNFET	The on-resistance of N-FET			120		m $\Omega$
tss	Soft-start time	IBAT=0 to IBAT=1200V/RPROG		20		us
tRECHRG	Recharge comparator filter time	VBAT from high to low	0.8	1.8	4	ms
tTERM	Termination comparator filter time	IBAT below ICHR/10	0.8	1.8	4	ms

### Principle

The SLM6510 is a 2A single cell Li-ion battery charger applied for 5V wall adapters. It utilizes 1.5MHz synchronous buck converter topology to reduce the power dissipation. It provides a 2A maximum charge current, and the charge current can be programmed by an external resistor.

The SLM6510 includes two Open-Drain charge status pins: Charge status indicator NCHRG and battery full status NSTDBY. The internal thermal regulation circuit reduces the programmed charge current if the die temperature attempts to rise above a preset value of approximately 145°C. This feature protects the SLM6510 from excessive temperature, and allows the user to push the limits of the power handling capability of a given circuit board without risk of damaging the SLM6510 or the external components.

The charge cycle begins when the voltage at the VCC pin rises above the threshold voltage. The CHRG pin outputs a logic low to indicate that the charge cycle is on going. If the battery voltage is below 2.9V, the charger goes into the fast charge constant-current mode, and the charge current is set by  $R_s$ . When the battery approaches the regulation voltage 4.2V, the charge current begins to decrease as the SLM6510 enters the constant-voltage mode. When the current drops to charge termination threshold, the charge cycle is terminated, and NCHRG pin turns into a high impedance state and NSTDBY pin outputs a logic low level.

The charge termination threshold is 10% of the current in constant current mode. The charge cycle can also be automatically restarted if the voltage of BAT pin falls below the recharge threshold.

The on-chip reference voltage, error amplifier and the resistor divider provide regulation voltage with 1% accuracy which can meet the requirement of lithium-ion and lithium polymer batteries. When the input voltage is not connected, or below VBAT, the charger goes into a sleep mode, dropping battery drain current to less than 3µA. This greatly reduces the current drain on the battery and increases the standby time. The charger can be shutdown by forcing the TS pin to GND.

### Programming Charging Current

The charge current is programmed by the resistor connected between VS pin and LX pin (figure 4).

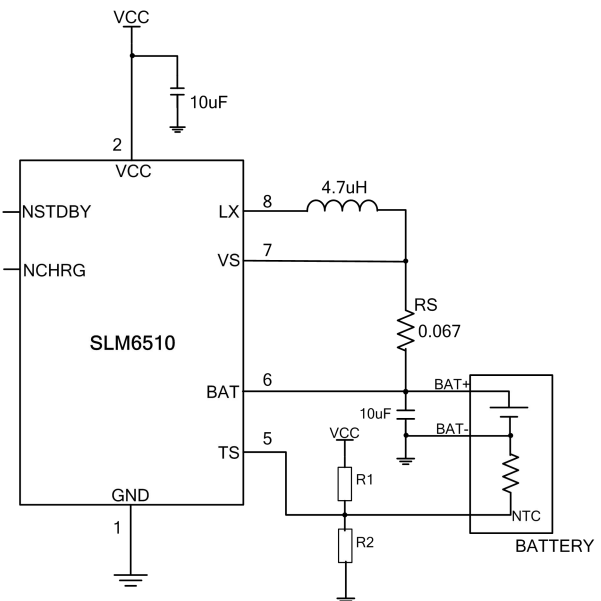

The program resistor and the charge current are calculated using the following formula:

$$R_s(\text{ohm}) = 0.1V / I_{\text{BAT}}(\text{A})$$

$R_S$ ( $\Omega$ )	$I_{BAT}$ (mA)
1	100
0.2	500
0.1	1000
0.067	1500
0.05	2000

Table 1:  $R_S$  and  $I_{BAT}$

### Charge Termination

A charge cycle is terminated when the charge current falls to 1/10th the programmed value after the final float voltage is reached. This condition is detected by using an internal filtered comparator to monitor the voltage of  $R_S$ . When the  $R_S$  voltage falls below 10mV for longer than  $t_{TERM}$  (typically 1.8mS), charging is terminated. The charge current is latched off and the SLM6510 enters standby mode, where the input supply current drops to 140 $\mu$ A (Note: C/10 termination is disabled in trickle charging and thermal limiting modes).

When charging, transient loads on the BAT pin can cause the  $R_S$  voltage to fall below 10mV for short periods of time before the DC charge current has dropped to 1/10th the programmed value. The 1.8mS filter time ( $t_{TERM}$ ) on the termination comparator ensures that the transient loads do not result in premature charge cycle termination. Once the average charge current drops below 1/10th the programmed value, the SLM6510 terminated the charge cycle and ceases to provide any current through the BAT pin. In this state all loads on the BAT pin must be supplied by the battery.

The SLM6510 constantly monitors the BAT pin voltage in standby mode. If this voltage drops below the 4.05V recharge threshold ( $V_{RECHRG}$ ), another charge cycle begins and current is once again supplied to the battery.

### Charge Status Indicator

SLM6510 has two open-drain status indicator output NCHRG and NSTDBY. NCHRG is pull-down when the SLM6510 in a charge cycle. In other status NCHRG in high impedance, NCHRG and NSTDBY are all in high impedance when the battery out of the normal temperature.

Represent in failure state, when TS pin in typical connecting and the charger with no battery: red LED and green LED all don't light.

The battery temperature sense function is disabled by connecting TS pin to Vcc. In this case, if the battery is not connected to charger, NCHRG pin outputs a PWM level to indicate no battery. If BAT pin connects a 10 $\mu$ F capacitor, the frequency of flicker about 1-4S, if status indicator is not required, it should be connected to GND. (Table 2)

Charge status	Red LED NCHRG	Green LED NSTDBY
charging	Light	Dark
Battery full	Dark	Light
Under-voltage, battery's temperature too high or too low, battery not connected (TS used)	Dark	Dark
BAT pin connects to 10uF capacitor, battery not connected, TS=VCC	Green LED lights, red LED flickers, F=1-4S	

Table 2: Charge status Indicator



### **Thermal Limiting**

An internal thermal feedback loop reduces the programmed charge current if the die temperature attempts to rise above a preset value of 140°C. The feature protects the SLM6510 from overheating and allows the user to push the limits of the power handling capability of a given circuit board without risk of damaging the SLM6510.

### **Battery Temperature Sense**

To prevent the damage caused by the very high or very low temperature done to the battery, the SLM6510 continuously senses battery temperature by measuring the voltage at TS pin determined by the voltage divider circuit and the battery's internal NTC sensor as shown in Figure 2.

The SLM6510 compares the voltage at TEMP pin ( $V_{TS}$ ) against its internal VLOW and VHIGH thresholds to determine if charging is allowed. In SLM6510, VLOW is fixed at (45%×Vcc), while VHIGH is fixed at (80%×Vcc). If  $V_{TS} < V_{LOW}$  or  $V_{TS} > V_{HIGH}$ , it indicates that the battery temperature is too high or too low and the charge cycle is suspended. The battery temperature sense function can be disabled by connecting TS pin to Vcc.

The values of R1 and R2 in figure 2 can be determined according to the assumed temperature monitor range and thermal resistor's values. Following is an example: Assume temperature monitor range is  $T_L \sim T_H$ , the thermal resistor in battery has negative temperature coefficient (NTC),  $R_{TL}$  is the resistance at  $T_L$ ,  $R_{TH}$  is the resistance at  $T_H$ , so  $R_{TL} > R_{TH}$ , then at temperature  $T_L$ , the voltage at TEMP pin is:

$$V_{TEMP_L} = \frac{R_2 \parallel R_{TL}}{R_1 + R_2 \parallel R_{TL}} \times V_{IN}$$

At temperature  $T_H$ , the voltage at TS pin is:

$$V_{TEMP_H} = \frac{R_2 \parallel R_{TH}}{R_1 + R_2 \parallel R_{TH}} \times V_{IN}$$

from  $V_{TEMP_L} = V_{HIGH} = k_2 \times V_{cc} (k_2 = 0.8)$

$V_{TEMP_H} = V_{LOW} = k_1 \times V_{cc} (k_1 = 0.45)$

derive:

$$R_1 = \frac{R_{TL} R_{TH} (K_2 - K_1)}{(R_{TL} - R_{TH}) K_1 K_2}$$

$$R_2 = \frac{R_{TL} R_{TH} (K_2 - K_1)}{R_{TL} (K_1 - K_1 K_2) - R_{TH} (K_2 - K_1 K_2)}$$

For positive temperature coefficient thermal resistor in battery, we have  $R_{TH} > R_{TL}$

$$R_1 = \frac{R_{TL} R_{TH} (K_2 - K_1)}{(R_{TH} - R_{TL}) K_1 K_2}$$

and we can calculate:

$$R_2 = \frac{R_{TL} R_{TH} (K_2 - K_1)}{R_{TH} (K_1 - K_1 K_2) - R_{TL} (K_2 - K_1 K_2)}$$

It is obvious that temperature monitor range is independent of power supply voltage VCC and it only depends on R1, R2,  $R_{TL}$  and  $R_{TH}$ : The values of  $R_{TH}$  and  $R_{TL}$  can be found in related battery handbook or deduced from testing data. In actual applications, if only one terminal temperature is concerned (protecting overheating), only R1 is needed.

### **Manual Termination**

At any time of the charging cycle will put the SLM6510 into disable mode through pulling TS pin to GND. This made the battery drain current to less than 2 $\mu$ A. To restart the charge cycle, set TS pin in high level or connect a programming resistor.

### **Over-current and Short-Circuit Protection**

SLM6510 includes several varieties of protection, In order to avoid damaging the SLM6510, the peak current through the chip is limited at 3.5A. When the voltage of BAT pin is lower than 1.2V, the SLM6510 will enter a short-circuit protection mode, and the current through the chip will be limited at 10% of the peak current which is about 350mA.

### **Under Voltage Lockout**

An internal under voltage lockout circuit monitors the input voltage and keeps the charger in shutdown mode until VCC rises above the under voltage lockout threshold. If the UVLO comparator is tripped, the charger will not come out of shutdown mode until VCC rises 120mV above the battery voltage.

### **Auto Restart**

Once charge is terminated, SLM6510 immediately use a 1.8ms filter time ( $t_{RECHARGE}$ ) comparator to monitor the voltage on BAT pin. If this voltage drops below the 4.05V recharge threshold (about between 80% and 90% of VCC), another charge cycle begins. This ensured the battery maintained (or approach) to a charge full status and avoid the requirement of restarting the periodic charging cycle. In the recharge cycle, NCHRG pin enters a pulled down status.

### **White LED Driver**

The SLM6510 can directly drive white LED if 4 dry batteries is in serial as the input (6V). As the white LED turn-on voltage is approximate 3.6V, and works in the constant current stage. SLM6510 is able to supply stable DC current for single white LED or multiple white LEDs in parallel, and provides a 4.2V over-voltage protection. The SLM6510 can drive the 0.5W-7W white LED, and the driving current is programmed by the value of RS.

### **Input and Output Capacitor**

Although a variety of types of capacitor can be used, power capacitor with high quality is recommended. Cautions are needed when using ceramic capacitor. Some ceramic capacitor may cause high EMI; therefore, under certain conditions high transient voltage may be caused to damage the chip. It is advised to use 47 $\mu$ F ceramic input capacitor, and 10 $\mu$ F ceramic output capacity for 2A applications. If you want to use electrolytic capacitors, a 0.1 $\mu$ F bypass capacitor is required, and place it as close as the chip.

### **Inductor Selection**

In order to guarantee the stability of the system, make sure the system works under CCM mode when in pre-charge and constant-current charge.

According to the inductor current formula:

$$\Delta I = \frac{1}{L \times FS} \left( \frac{V_{IN} - V_{BAT}}{V_{IN}} \right) \times V_{BAT}$$

Where  $\Delta I$  is the inductor ripple current, FS

It is advised to take  $\Delta I$  as 1/10 of the programmed charge current to ensure the system works under CCM mode in both pre-charge and constant current charge. Then based on the value of  $V_{in}$ , the value of inductor can be calculated.

The value of the inductor should be between 2.2uH and 10uH. 3.3uH is recommended for 2A applications.

The rated current of the inductor must be higher than the programmed charge current, and lower resistance is advised.

### **Heat Dissipation**

In order to maximize the charge current, PC board layout design should be optimized to provide IC within DFN8 package effective heat dissipation.

The thermal path for the heat generated by IC is from the die to lead frame, and finally to the PC board copper through the bottom heat sink. As the heat sink of IC, the copper pads of PC board should be as wide as possible, and extends out to other larger copper areas to dissipate heat into ambient environment

Another effective way to improve the heat dissipation ability of charger is to placing via to the internal or back layer of PC board, as figure 3 illustrates, place a pad as the heat sink of SLM6510, and then place 4 cooling holes spacing on the pad. Solder should be injected into the cooling holes from the back layer of PC board to ensure that the bottom heat sink of the SLM6510 is completed connected to the cooling pad.

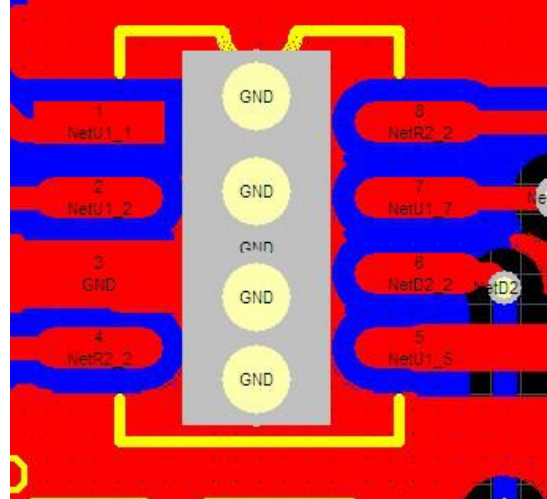
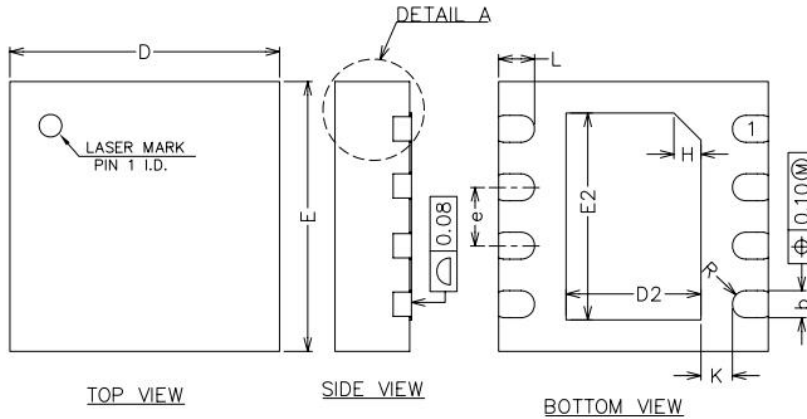

Figure 5

Other heat sources not related to the IC should also be considered when designing PC board layout, as they might influence the overall temperature rise and the maximum charge current.

### Packaging Information

#### 8-Pin DFN8 Package (Unit mm)



COMMON DIMENSIONS  
(UNITS OF MEASURE=MILLIMETER)

SYMBOL	MIN	NOM	MAX
A	0.80	0.85	0.90
A1	0.00	0.02	0.05
A3	0.20REF		
b	0.25	0.30	0.35
D	2.90	3.00	3.10
E	2.90	3.00	3.10
D2	1.40	1.50	1.60
E2	2.20	2.30	2.40
e	0.55	0.65	0.75
H	0.30REF		
K	0.25	0.35	0.45
L	0.35	0.40	0.45
R	0.13	-	-

